

Tehniskie noteikumi L grupas automašīnām

Stājās spēkā ar 01.01.2023

Papildinājums 10. Bremžu sistēma	Annex 10 braking system
<p>Bremžu pedāli drīkst izgatavot no tērauda vai alumīnija, ar nosacījumu ka pedāļa stiprināšanas vieta netiek mainīta.</p> <p>Nedrīkst mainīt attālumu starp pedāļa stiprināšanas asi un bremžu cilindru pievadu.</p> <p>Svirai jābūt izgatavotai no viengabala materiāla.</p> <p>Tērauda sviras biezums nedrīkst būt mazāks par 5.00 mm</p> <p>Alumīnija sviras biezums nedrīkst būt mazāks par 8.00 mm</p> <p>Bremžu pedāļa pēdas drīkst izgatavot no tērauda un alumīnija:</p> <p>tērauda pēdas biezums nedrīkst būt mazāks par 3.00mm</p> <p>alumīnija pēdas biezums nedrīkst būt mazāks par 5.00mm</p> <p>bremžu pedāļa pēdas laukumu drīkst palielināt ar nosacījumu, ka tas netraucē blakus pedāļiem.</p> <p>Tehniskais Komisārs: sacensību tehniskajā pārbaudē, konstatējot neatbilstību rasējumam var liegt dalību sacīkstēs.</p>	<p>The brake pedal may be made of steel or aluminum, taking into consideration that pedal mounting location is not changed.</p> <p>It is not permitted to change the distance between the pedal mounting axis and the brake cylinder drive.</p> <p>The lever must be made of one-piece material.</p> <p>Thickness of the steel lever must be at least 5.00 mm.</p> <p>Thickness of the aluminum lever must be at least 8.00 mm.</p> <p>Foot pad of the brake pedal can be made of steel and aluminum:</p> <p>thickness of the steel foot pad must be at least 3.00 mm</p> <p>thickness of the aluminum foot pad must be at least 5.00 mm</p> <p>it is allowed to enlarge foot pad area of the brake pedal, taking into consideration that it does not interfere with nearby pedals.</p> <p>Chief Scrutineer: if a discrepancy with the drawing is found at the scrutineering during the competition, participation in the competition may be prohibited.</p>

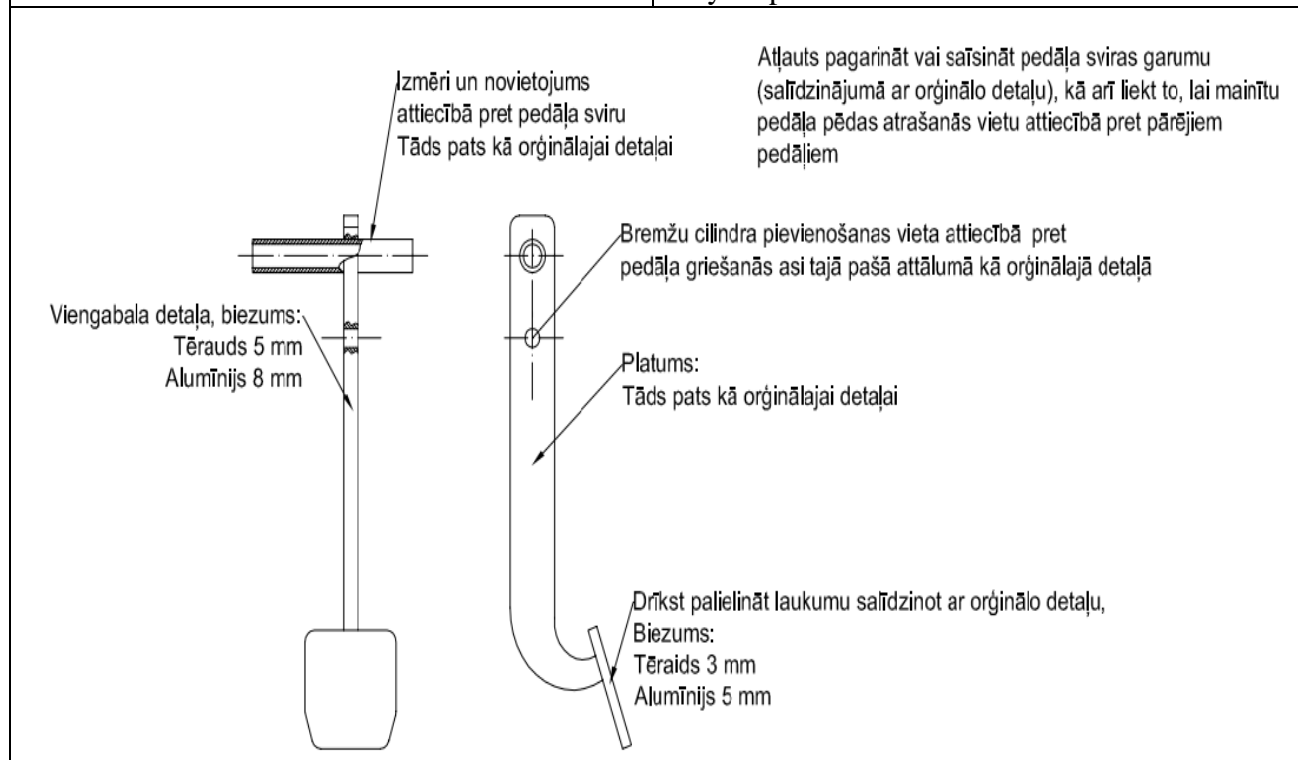

24. Drošības jostas un sēdekļi	24. Seat belts and seats
<p>24.8 Papildināt ar sekojošu tekstu: 2 WD automašīnām līdz 2000 cm³ atļauts piedalīties LRC posmos ar sporta sēdekļiem kuriem ir beigusies homologācija. Sēdeklim ir jābūt homologācijas uzlīmei ar skaidri salasāmu informāciju par sporta sēdekli. Sporta sēdeklis nedrīkst būt mehāniski bojāts. Tehniskai Komisārs: sacensību tehniskajā pārbaudē, konstatējot mehāniskus bojājumus sporta sēdeklim var liegt dalību sacensībās. Stingri rekomendējam drošības ekipējumu izmantot atbilstoši Tehniskiem noteikumiem J253 pielikumam, kas ir saskaņā ar LAF un FIA.</p>	<p>24.8 To be supplemented with following text: 2WD vehicles up to 2000 cm³ with sporting seats with expired homologation are allowed to participate in the events of LRC. Seat must have a homologation sticker with clearly legible information about the sporting seat. Sporting seat can not be mechanically damaged. Chief Scrutineer: if mechanical damages of the sporting seat are found at the scrutineering during the competition, participation in the competition may be prohibited. It is strongly recommended to use safety equipment in accordance to Appendix J253 of Technical Regulations, which compies with both – LAF and FIA.</p>