

INITIAL RESTRAINT ADJUSTMENT DURING INSTALLATION

While first installing your racing harness the following items may require minor adjustments to the belts.

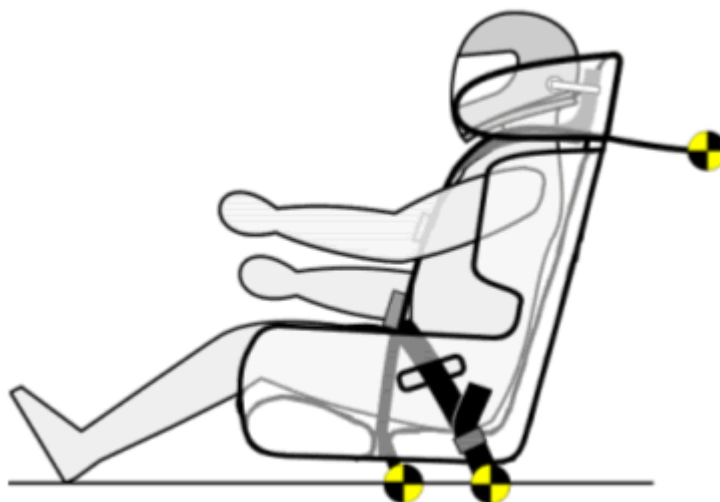

- Shoulder belt tilt lock adjusters must be positioned 250 mm (10") below the collar bone or even lower.
- If a **HANS®** is worn, the adjuster must be positioned 70 mm on the yoke end of the **HANS®**.
- For a **HANS specific double-shoulder belt** system, the adjuster has to be positioned so the merge between the "HANS-belt" and the "body-belt" must be located at a certain distance below the **HANS®** yoke tips. For more details see instructions in section "**Wearing your Racing Harness safe**"
- **Lap belt tilt lock adjusters** must not be positioned within the openings of the bucket seats. Adjusters must be either outside of the seat at a minimum distance of 40 mm (1.5") from the opening or close to the rotary buckle inside the seat.
- **Anti-sub strap tilt lock adjusters** are recommended to be positioned either in the opening of the seat pan or right above. This position will allow adjustment without interfering in an uncomfortable manner with your upper thighs.

SAFETY INSTRUCTIONS

Roll cage bars used to mount the shoulder belts must be homologated by the roll cage manufacturer for such use. Each shoulder and lap belt anchor point must withstand a minimum load of 14,7 kN (3.240 lbs). Each anti-submarining anchor point must withstand a minimum load of 7,2 kN (1.650 lbs). Any drilled hole for racing harness attachment must be strengthened by a reinforcement plate meeting FIA specification (see list of accessories on Page 62) SCHROTH recommends, whenever possible and suitable, the use of existing factory provided anchor points for the lap- and shoulder belts.

Wrap Systems to roll bar installation and brackets assembly

3-bar slide wrap

This installation is commonly used for

- shoulder strap roll cage installation
- and
- to assemble open strap ends to brackets.

Do not install a lap belt directly to a roll cage by wrap around technique.

SAFETY INSTRUCTIONS

Die Installation von Schultergurten mittels dieser Schlaufftechnik ist nur zulässig, wenn

- das Querrohr zur Verankerung mindestens 200 mm hinter der Sitzlehne liegt
- der Sitz mit einer ausgesprochen wirkungsvollen Schulterunterstützung gegen Seitwärtsbewegung während eines Seitenaufpralls versehen ist.

WHAT DO YOU NEED:

- **open strap ends**
 - **a 3-bar slide for either 50mm (2") or 75mm (3") wide webbing**
- and
- **an accessible roll cage bar**
- or
- **an homologated bracket made by SCHROTH.**

Racing harness with end brackets assembled to the shoulder belts by a 3-bar slide allow to dismount the brackets and use the 3-bar slide for wrap around installation directly to the roll cage. Also brackets can be exchanged e.g. from a snap-on to a bolt-in bracket or vice versa.

Sfi 16.5/NASCAR Regulations:

Brackets with at least 50 mm (2") wide slots are required for use with 75 mm (3") wide webbing. Snap-on brackets are not allowed.

1. make sure the protruding strap end is long enough to have sufficient webbing length available for the following wrapping procedure. A minimum of 360 – 400 mm (14" – 16") is recommended.
2. the 3-bar slide shall be positioned as close as possible to either the roll cage bar or to the end bracket.
3. wrap the free strap end from underneath around the roll cage bar or through the webbing slot of an end bracket.
4. in case of the combination of a 50 mm bracket slot and 75 mm webbing, fold the webbing in as shown.

INSTALLATION STEPS:

1. slide the webbing through slot 1 and 2 as shown

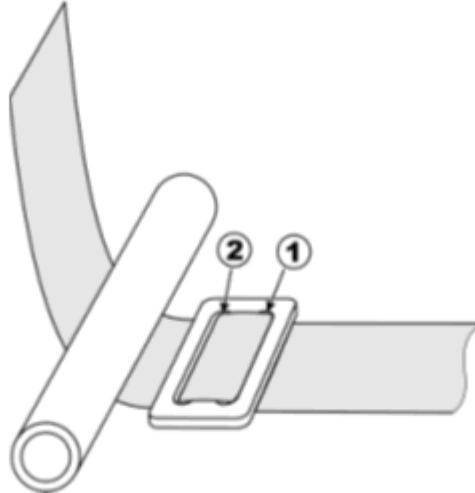

2. make sure the protruding strap end is long enough to have sufficient webbing length available for the following wrapping procedure. A minimum of 360 – 400 mm (14" – 16") is recommended.
3. the 3-bar slide shall be positioned as close as possible to either the roll cage bar or to the end bracket.
4. wrap the free strap end from underneath around the roll cage bar or through the webbing slot of an end bracket.
5. in case of the combination of a 50 mm bracket slot and 75 mm webbing, fold the webbing in as shown.

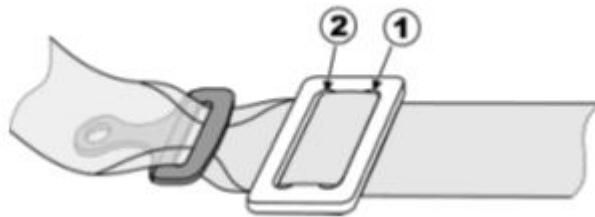

6. wrap webbing back through slot 2 and 1.

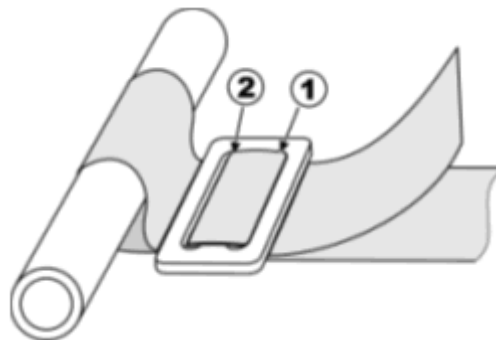

7. fold strap end back and run it through slot 2 again.
8. make sure the strap end protrudes at least 100 mm (4") or even longer from slot 2. If it is less than 100 mm disassemble and start over again. If longer, roll in the strap end and fix it by a cable tie to the shoulder belt.

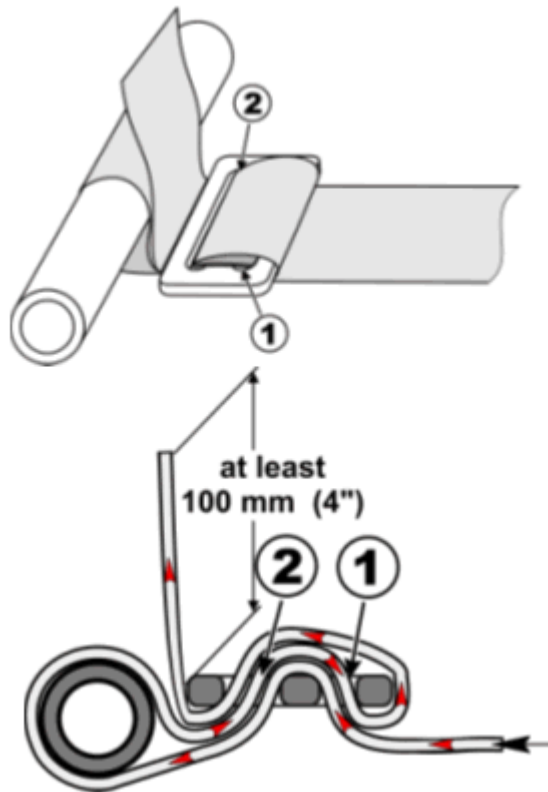

9. Check again for proper shoulder belt tilt lock adjuster positioning and for the 3-bar slide to be as close as possible to the roll cage bar or end bracket.

Light Weight D-Ring [50 mm (2") and 75 mm (3")] Wrap

This installation is to be used for

- shoulder strap installation to
 - roll cages
 - elbow brackets in open wheel race cars
 - SCHROTH HANS® adaptor for open wheel race cars
- as 50 mm [2"] version also to assemble open strap ends to brackets.

Do not install a lap belt directly to a roll cage by wrap around technique.

What do you need:

- open strap ends
- the D-Ring type slide for either 50 mm (2") or 75 mm (3") wide webbing
- an accessible roll cage bar

or

- an homologated bracket made by SCHROTH.

Racing harnesses with an end bracket assembled to the shoulder belt by a D-Ring slide, allow to dismount the bracket and use the D-Ring slide for wrap around installation directly to the roll cage bar. The diameter of that bar shall not exceed 50 mm [2"].

This D-Ring slide system is not to be used to attach 75 mm [3"] webbing to brackets with less than 3" webbing wide slots.

WRAPPING INSTRUCTIONS:

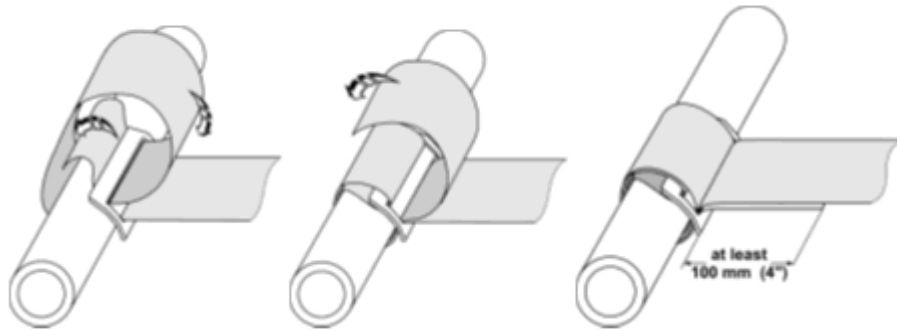

1. position D-Ring slide to roll bar with wider bar atop
2. slide a minimum of 600mm (24") of strap length through D-Ring slide and from underneath around roll bar [first loop]
3. slide strap from atop through D-Ring slot towards roll bar and back between roll bar and first loop until it protrudes from slot in D-Ring slide.
4. Pull at shoulder belt to check that wrap will tighten when being loaded.
5. Wrap strap end around roll bar again [third loop] and thread through D-Ring slide again. Shoulder belt is now sandwiched between first loop webbing and protruding strap end.
6. Make sure strap end protrudes at least 100 mm [4"]

 **WARNING**

Incorrect wrapping or 3-bar slides wrapped too far away from the roll cage bar or from any bracket may allow webbing to slide during an accident. Extra elongation will occur which may reduce the effectiveness of the racing harness and the HANS®, if worn. Shoulder belts may slide off the HANS® or will give extra slack allowing possible head and chest impact into the steering wheel. Severe injuries or death may occur.

WRONG INSTALLATIONS

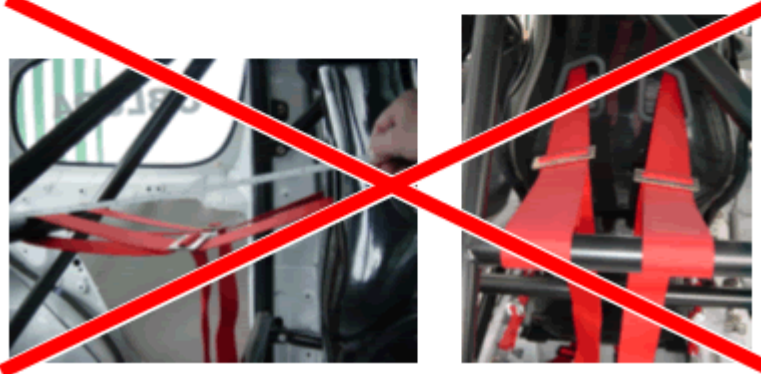

Webbing should be crossed if the distance from the seat openings to the mounting bolt point or harness bar exceeds 450 mm (18").

When mounting to a harness bar with a wrap mount and the distance to the bar from the seat is less than 450 mm (18"), a section of roll bar padding, fixed with cable ties, should be added to the outside of each of the shoulder harnesses to ensure that they can not further separate when unloaded.

3-Bar Adjusters pictured in the examples are not positioned next to the bar and the final locking portion of the wrap has not been completed. This will result in significant slippage through the adjuster and significantly more elongation of the shoulder belts.

C O R R E C T I N S T A L L A T I O N

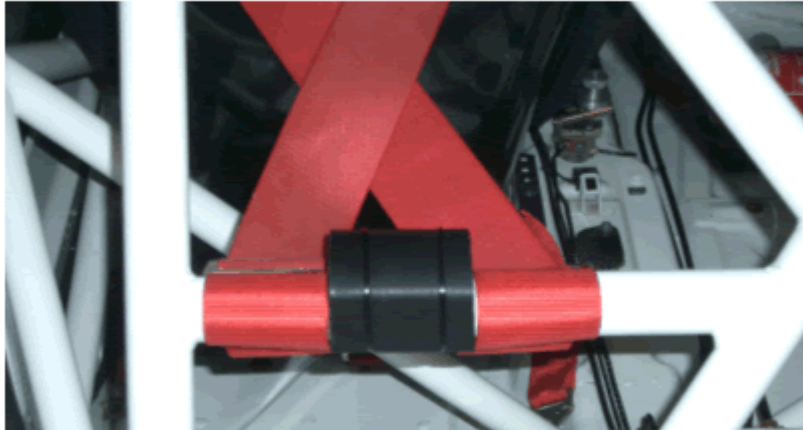

example for a spreader using FIA 8857-2001 padding material

BOLT-IN WRAP BRACKET ASSEMBLING

What do you need:

- Racing harness with 50 mm (2") or 75 mm (3") webbing and open strap ends
- a bolt-in wrap bracket with 50 mm (2") webbing slot [B 63]
- or
- a bolt-in wrap bracket with 75 mm (3") webbing slot [B 40]

Installation procedure

1. webbing shall wrap from the body facing side of bracket up into slot 1
2. pull through approx. 270 mm (11") and fold down through slot 3 temporarily leaving 50 mm (2") of slack.

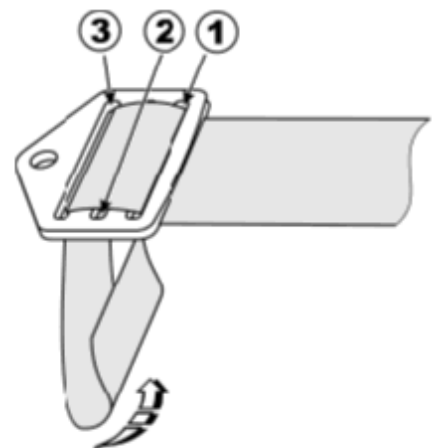

3. fold back up from the body side through slot 1 and back down through slot 2
4. fold back through slot 3 and finally through slot 1

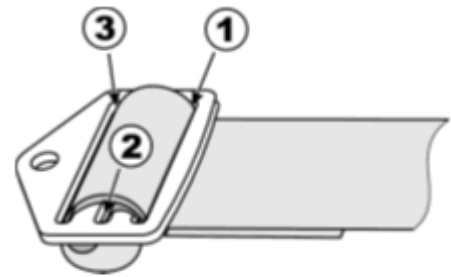

5. pull the lap belt firmly to ensure the wrap is properly tight.

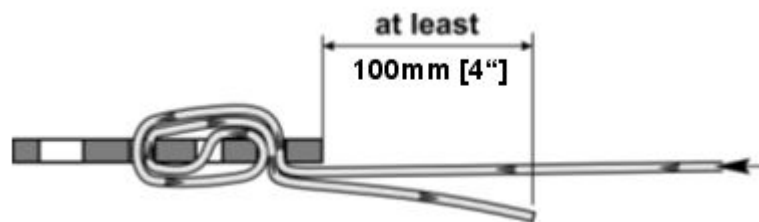
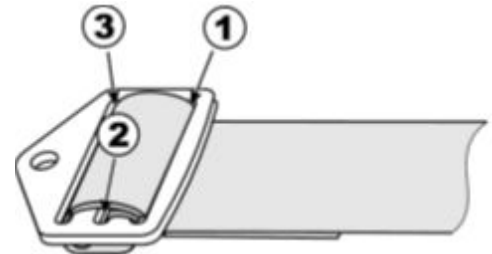

6. make sure the protruding strap end is at least 100 mm (4") long

The webbing must be wrapped tightly!

SAFETY INSTRUCTIONS

The protruding end must be sandwiched between the load taking strap end and an inner webbing fold through slot 1. If this is not achieved, check again for proper routing.

LIGHT WEIGHT WRAP SYSTEM [LV 4]

This light weight system assembles directly to 50 mm (2") slot brackets and is therefore commonly used by SCHROTH for anti-sub strap bracket and for the "Flexi-Belt™" assembly of both, the buckle latch and the bracket.

This system is also absolutely micro slip free.

For the light weight wrap system you need:

- Racing harness with 50 mm (2") webbing and open strap ends
- a bracket or latch with a 50 mm (2") strap slot
- a wrap hardware (Part No. LV 4)

Wrapping instructions

1. Place LV 4 with its thicker bar onto the bracket/latch.
2. Run strap end through slot at LV 4 and then from underneath through webbing slot at bracket/latch. Pull through at least 200 mm (8") of webbing. Fold strap end over the wider bar of LV 4 and back through the gap between bracket/latch bar and LV 4 bar.
3. Slide strap end further through the webbing slot at bracket/latch and then fold the strap end through the slot at LV 4.
4. Pull at the load taking strap and the bracket/latch to make sure, the webbing is properly clamped by the wrap hardware.
5. If this is not achieved, check for proper strap routing and follow these instructions step by step again.
6. If the protruding webbing is significant longer than the minimum of 50 mm [2"], you may fold it over again, run it through webbing slot of the bracket/latch and again back and through the webbing slot at LV 4.

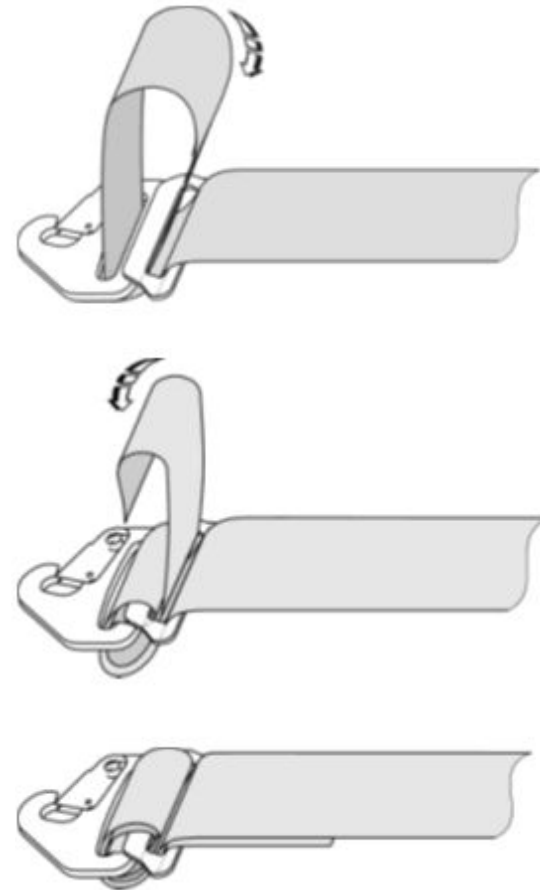

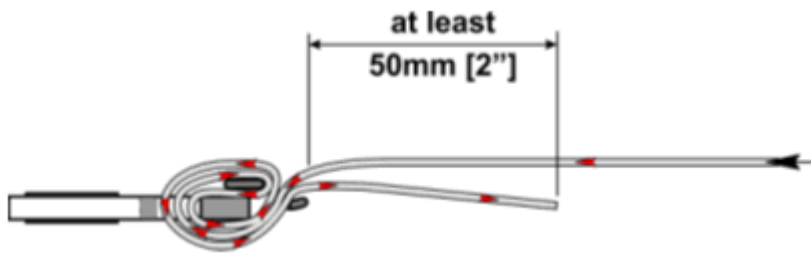

7. In this case, the strap end now protrudes from the down side of the LV 4.

The webbing must be wrapped tightly!

Flexi Belt™ assembling via Light Weight Wrap System

- Flexi Belt™ allows you to assemble the lap belt either as a pull-up or a pull-down version.
- As end brackets you can assemble SCHROTH snap-hook bracket or any other SCHROTH bracket with a 50 mm (2") webbing slot.
- For swivelling bolt-on installation, use the wrap bracket shown in section **Bolt-in Wrap Bracket assembling**. The wrap hardware LV 4 is not to be used with this bracket. Follow assembly instructions for **Bolt-in Wrap Bracket assembling**.



- Follow the wrapping instructions above at both strap ends.
- Make sure, when the latch is buckled in, the bent part of the buckle latch faces towards the body. See figure below.

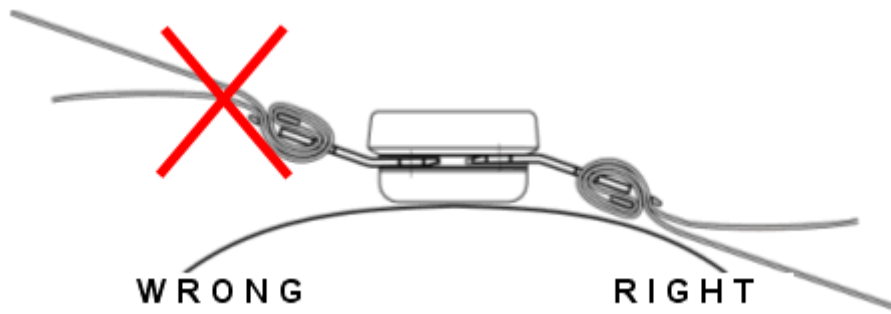

- In a pull-down configuration the adjuster shall be as close as possible located to the buckle
- In a pull-up assembly make sure, the adjuster is well separated from the strap hole in the bucket seat so the adjuster will not interfere with the seat bucket during a crash. See section “**Anchorage Locations and Geometries**”

Double Bar Lap Belt Installation

This installation system is only used in some open wheel race cars.

SAFETY
INSTRUCTIONS

- Bars must not bend under strap load of at least 14.7 kN.
- All edges must be appropriately rounded (>1,5 mm radius)
- The bars must directly clamp on to each other firmly clamping the webbing.
- Make sure the belt is correctly routed as recommended by FIA and shown in following sketch.

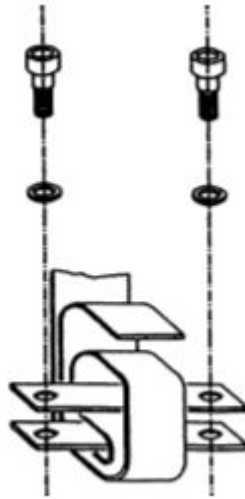

WARNING

Improper routing the webbing/belt may result in attachment failure during an accident. Webbing may either slide through the assembly or may be cut by the metal bars. Severe injuries or death may occur.

EYE BOLT INSTALLATION FOR SNAP-ON AND CARABINE BRACKETS

Eye bolts for snap-on brackets may be installed either to

- anchor point provided by the car manufacturer or
- anchor points provided by the roll cage manufacturer
- a newly created anchor point in conjunction with a proper reinforcement plate [see “Accessories and Spare Parts”]

Installation Material and Tooling needed:

- Eye bolt
- Spring washer (1 or 2 ea)
- strong screw driver or metal bar or wrench for eye bolt tightening
- in case of newly created anchor point: reinforcement plate
- Assemble eye bolt and spring washer as shown in sketch beside.
- Bolt in eye bolt and tighten securely. The optimum torque setting is 40 Nm (350 lbinch). Pull either screw driver or similar tool through eye and turn clockwise to tighten the bolt securely.
- Make sure the eye's ring is pointing in direction of pull as shown in drawing below. This position will reduce the risk of unintended loosening of the eye bolt by torque forces applied by the harness during racing. If you cannot achieve this position by further tightening or loosening the bolt by a maximum of j turn, dismount the eye bolt and use 2 spring washers to come closer to the recommended position.

If you need a raised snap-on point, some of the SCHROTH stainless steel bolt-in brackets can be used as adapters. For further information see section “Bolt-in Brackets”.

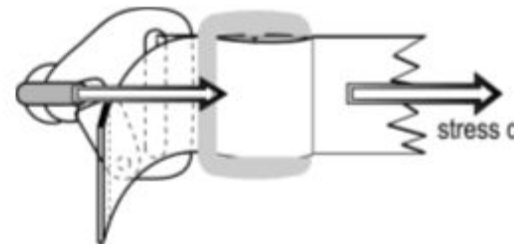

1. The webbing must always be positioned on the smaller section of the triangular carabiner. The lock nut must always be positioned in the free section between the eye bolt and the webbing.
2. The lock nut always must fully catch the counter thread. No thread turn must remain free from the lock nut.

Lock Nut Carabiner

Definitions:

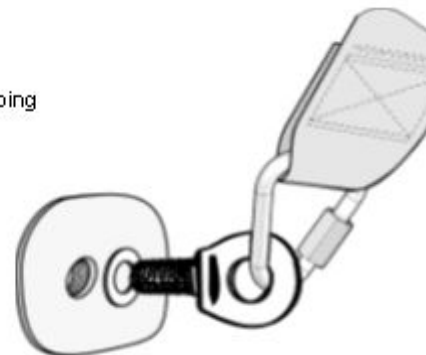

Bolt-in Brackets

SAFETY INSTRUCTIONS

All brackets must be installed in direction of pull to avoid extensive stress to the anchor points during driving [fatigue stress] or during an accident..

Brackets for lap belt installation must either swivel [NASCAR requirement] or must be able to provide alignment during a crash. Therefore SCHROTH provides bolt-in brackets only with sleeved bushings for swivelling or alternatively special designed stainless steel brackets which can be aligned with the direction of pull at the time of installation.



WRONG



WRONG

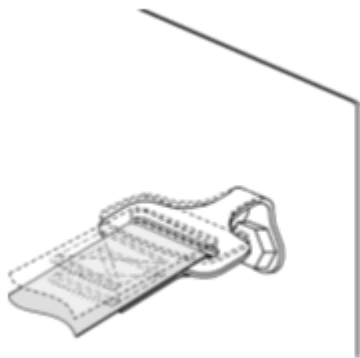

CORRECT

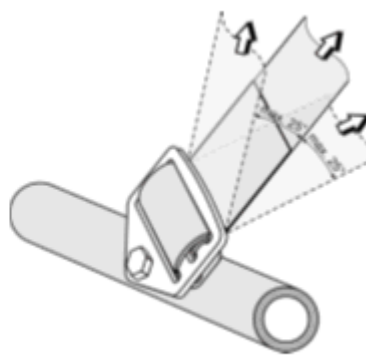

CORRECT

Stainless Steel Bracket installation

These brackets are commonly used in SCHROTH street legal harnesses [FE models] and other bolt-on installations.

The brackets are made from special stainless steel so they can be pre-bent at installation to the direction of pull of the webbing where it is attached to the bracket as the belt flows over the body. This will help to avoid straps from dumping/loading into bracket slot edges and reduces uneven load to attached webbing. This significantly reduces the risk of webbing tear and cut.

Proper alignment of the webbing pull through the bracket reduces the bending stress [risk of fatigue cracks] to anchor points during driving and during an accident.

For 50 mm [2"] wide webbing two versions are available and used as sewn in brackets:

- bracket B 23 A, coming with a 12,2 mm [15/32"] hole for use of 3/8", 10 mm or 7/16" and 15/32" bolts.
- bracket B 23 B, same as above but with a 12,8mm [1/2"] hole for use of 7/16" or 1/2" bolts.

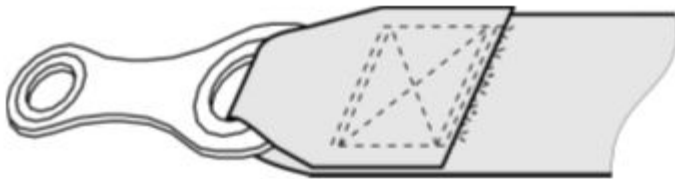

For 75 mm [3"] webbing either sewn in or assembled bracket B 23 C is available. Assembly is commonly done by using a 3-bar slide. This bracket comes with a 12,8 mm [1/2"] hole for use of 7/16" or S" bolts.

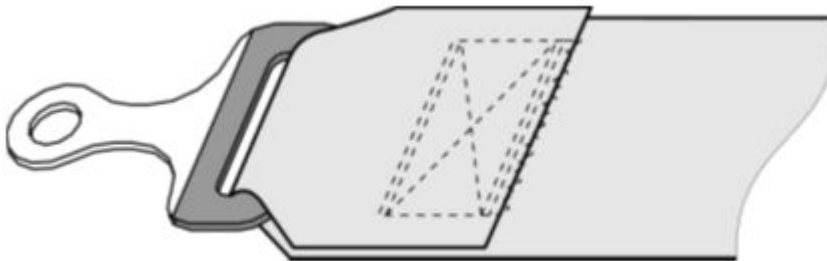

In case the bolt diameter to be used does not fit with the bracket hole, contact your dealer or the importer for help.

WARNING

Never try to drill a larger bolt hole into any bracket. The bracket may be weakened or stick to your drill bit and the bracket and attached webbing and its hardware may spin and may cause severely injuries or death.

Needed equipment:

- hammer
- bench vice
- gripper/pliers

Bending Procedure

- Determine direction the bracket should face when being installed.
- Use bench vice, gripper and hammer to bend and wind the bracket as needed.
- Make sure the bend allows enough space for the bolt head and wrench.
- Bracket can be wound and bent up to 90° in either direction.

WARNING

Do not bend bracket back and forth several times. Multiple bends in opposite directions will weaken the material and the bracket may fail during an accident.

Make sure the webbing is not damaged during bracket bending or the webbing may fail during an accident.

Severe injury or death may occur.

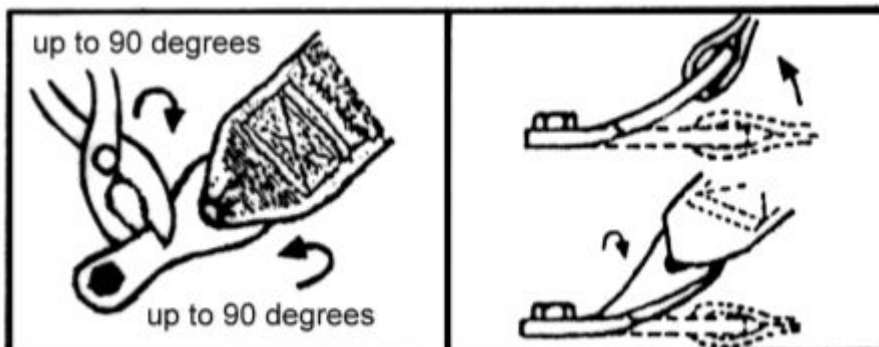



- Only use bolts as specified above.
- Make sure the bolt diameter fits to the thread hole. Heed all information in section **“Important Information About Bolts and Torques”**.
- Use e.g. “Loctite 243” to secure bolt.
- Tighten with the adequate torque to the bolt size selected.
- Prior to final torque of securing bolt, position the bend of the bracket so it points into the direction of pull. Large pliers work well for this purpose.

B 23 A and B 23 B bracket installation for snap-on use.

B 23 A and B 23 B brackets allow snap-on installation where eye bolts do not have enough space or access to the anchor point or if restricted seat adjustment is impaired when an eye bolt is installed. Brackets are available as Installation Kit with B 23 A and with B 23 B.

For installation and bending of brackets follow the instructions under the section "**Stainless Steel Bracket installation**" above.



Bolt-in swivelling Wrap Brackets

The SCHROTH wrap brackets are designed for fully swivelling installation.

- Versions B 63 for 50 mm [2"] and B 40 for 75 mm [3"] webbing are available.
- The bushing sleeves supplied with each bracket allow swivelling installation with bolt dimensions of 8 mm, 10 mm, 5/16", 3/8", 7/16" and 1/2".
- The wrap webbing assembly allows fine adjustments for lap belt tilt-lock adjuster positioning or lap belt length.

For installation you need:

- open end webbing either 50 mm [2"] or 75 mm [3"]
- bracket matching the webbing width
- bolts of size and length fitting to the anchorage threads
- bushing sleeves and washers from the installation kit matching the bolts.

Installation

- Anchor point positioning has to provide a bracket pointing toward the driver as shown in sketches.
- Webbing shall not run off the bracket under an angle of more than plus or minus 25°.

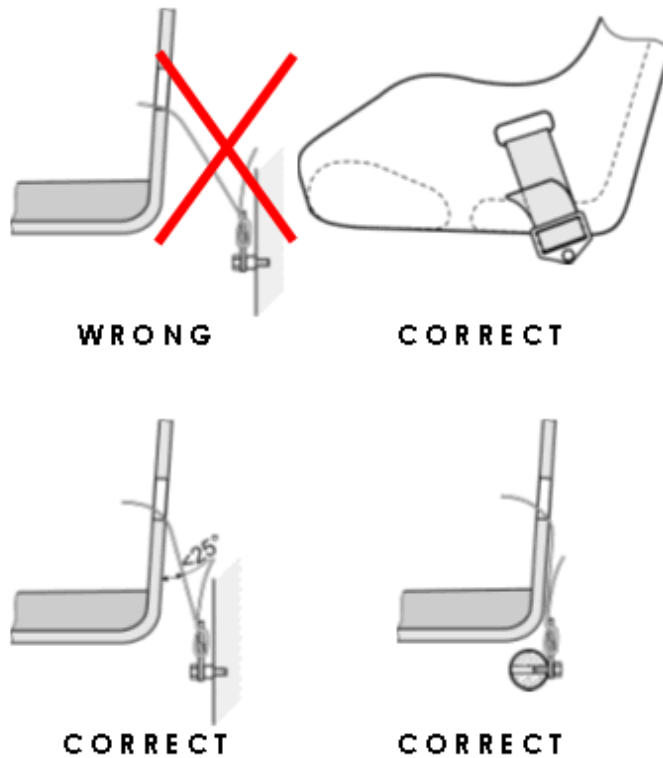

Bracket Installation

- In cases where other than 7/16" 20 UNF threaded bolts will be used, make sure bolts are in the range of those listed above and that they match the anchorage threads in size.
- Follow all instructions and information, SAFETY INSTRUCTIONS and WARNING boxes provided under section "**Important Information about Bolts and Torques**".
- In case you need brackets with a diameter not fitting the bolt size, contact your dealer or importer of this product.
- Choose the matching bushing sleeves and washers from the installation kit for the bolt diameter used [1/2" washer not included].
- Assemble as shown in drawing below.

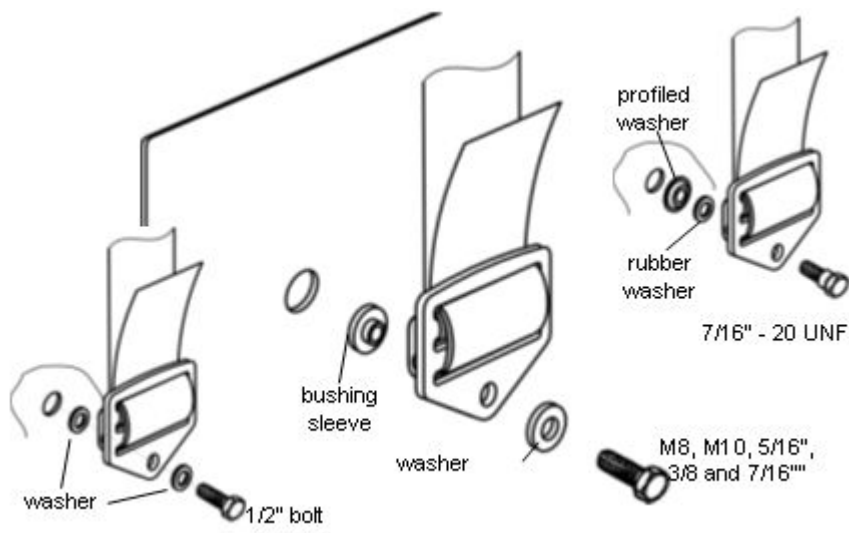

- 1.1. Use e.g. "Loctite 243" to secure bolt.
- 1.2. Bolt in and tighten bolts with torques as listed in section "**Important Information About Bolts and Torques**", at 1/2" bolt installation allows looseness for bracket to swivel.
- 1.3. Check for unrestricted bracket swivelling and webbing alignment in expected direction of pull.
- 1.4. In case brackets do not swivel check for the proper assembling and torque or any other reason which may restrict the bracket from free swivelling. Change assembly and installation to provide proper swivelling.



Light Weight Bolt-in Brackets

{Not for NASCAR!}

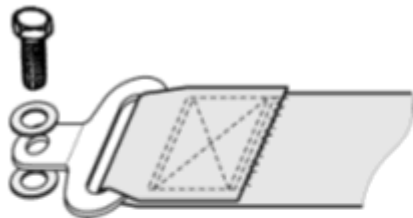

**B 33 [not for
Sfi 16.5/NASCAR]**

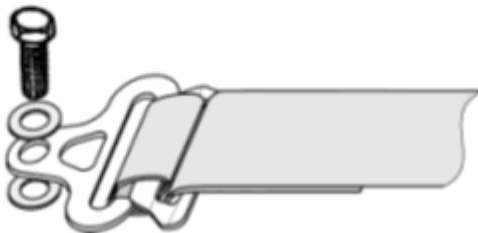

B 64

1. B 33 brackets are used in made to measure racing harnesses only.
2. These brackets are commonly used for 50 mm [2"] and for a fold in 75 mm [3"] webbing sewn in assembly.
3. B 64.20.xx can also be used in conjunction with a D-Ring LV 4 for a wrap mount with 50 mm (2") webbing.
4. Bolt hole can vary for 8 mm or equivalent 5/16" or 10 mm or 3/8" bolt diameter.
5. Bolts and washers are not supplied by SCHROTH.
6. Choose from bolts with grade 8.8 or up only.

7. Make sure the bend of the bracket aligns to the direction of pull deviating not more than plus or minus 25°.
8. Before fully tightening position the bracket to align with direction of pull.
9. Use e.g. "Loctite 243" to secure bolt.
10. Tighten the bolt. Follow all instructions and information, WARNINGS, WAIVER and SAFETY INSTRUCTIONS boxes provided under section "**Important Information About Bolts and Torques**".
11. Make sure the bracket has not turned out of direction of pull. If it has, repeat the procedure as described.

Bolt-in Bracket B 24.15.13

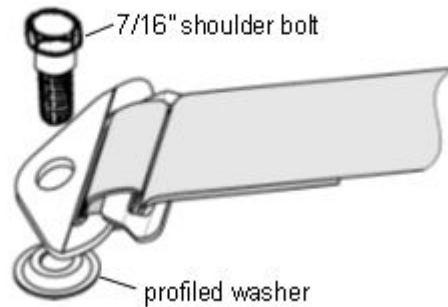

1. This bracket is used in made to measure racing harnesses only.
2. is commonly used for 50 mm [2"] and for a fold in 75 mm [3"] sewn in assembly.
3. It can also be used in conjunction with 50 mm [2"] and 75 mm [3"] webbing 3-bar slide wrap mount or 50 mm [2"] webbing D-Ring [LV 4] wrap mount.
4. 7/16" 20 UNF shoulder bolt and provided washer is standard.
5. Bushing sleeves for 8 mm, 5/16"; or 10 mm/5/8" bolts are available optional. Bolts will not be supplied by SCHROTH. Choose from bolts with grade 8.8 or up only. For installation follow assemblies shown in section "Bracket Installation".
6. Make sure the bend of the bracket aligns to the direction of pull deviating not more than plus or minus 25°.
7. Use e.g. "Loctite 243" to secure bolt.
8. Tighten the bolt. Follow all instructions and information, WARNINGS, WAIVER and SAFETY INSTRUCTIONS boxes provided under section "**Important Information About Bolts and Torques**".
9. Make sure the bracket can swivel after bolt is tightened.

Anti-sub Strap twin bracket installation

A twin bracket installation is used for 6-point anti-sub straps of all kind.

It allows easier installation because the two brackets will clamp the webbing while it is being bolted in place.

The twin bracket system is also light and flat and therefore commonly used in open wheel racecars or in cars where drivers are sitting quite low in the chassis.

- Twin brackets are available with 20° and 45° bends.
- 20° bend twin brackets are to be used for rearward routed anti-sub straps [typical Formula Belt installation]
- 45° twin brackets to be used for downward installation as suggested for T-bar and Hybrid™ versions.
- All standard catalogue formula models come with 50 mm [2"] webbing and matching twin brackets. If specified so, made to measure racing harnesses can come with 44 mm anti-sub straps and matching brackets, except Hybrid™ models. Formula and Hybrid™ versions are not interchangeable.
- Twin brackets are prepared for 8 mm [5/16"] bolts [10 mm optional].
- 8 mm bolts and matching reinforcement plates are supplied with racing harnesses.

For installation you need:

- anti-sub open end straps
- 4x twin brackets
- 2x bolts 8mm as supplied or 5/16" grade 8.8 or 10.2
- 2x spring washer matching bolt diameter
- 2x reinforcement plate with 8 mm thread [SCHROTH PIN 01344, for 8 mm bolt use only]

Installation

1. Select anchorage position meeting the geometrical requirements described in section "**Anchorage Locations and Geometries**" for 6-point anti-sub strap routing.
2. Make sure the anchor points are symmetrically aligned to the seat.
3. If you have to create anchor points by yourself, strictly follow the procedures and WARNINGS in section "**Anchorage Locations and Geometries**".
4. Select direction of angled brackets. The twin brackets must point towards the strap slot in the seat when being installed.
5. Properly position anti-sub strap so it will correctly engage the buckle.
6. Route webbing through brackets by following these instructions:
 - a] position both brackets onto each other with the angled bend pointing as selected above [4]. You will have an "outer" and an "inner" bracket,
 - b] run webbing from outside through slots of both brackets and fold over.
 - c] Run webbing back through gap between both brackets and through slot of outer bracket.
 - d] Pull webbing through to adjust the proper length.

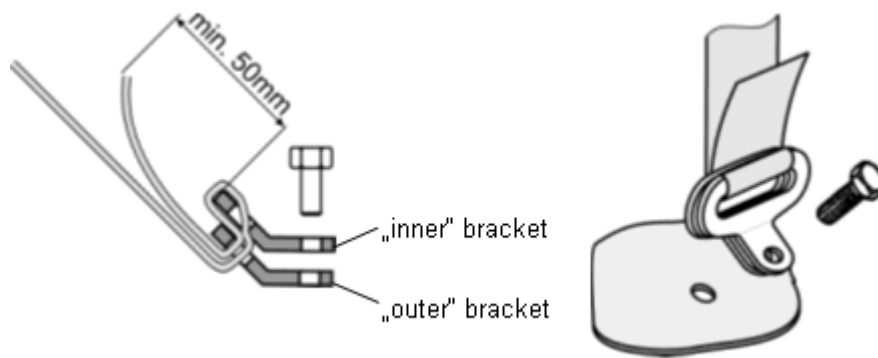

1. Use e.g. "Loctite 243" to secure bolt.
2. Bolt-in both and tighten. Follow all information as well as SAFETY INSTRUCTIONS and WARNING boxes provided under section titled "**Important Information about Bolts and Torques**".
3. Make sure the brackets stay positioned in the direction of pull.

Bolt-in Bracket B 18

This bracket is mainly used for 5-point anti-sub straps.
Its 45° angularity allows flat installation on the chassis floor with the webbing routing upwards.

- Select the anchor point position meeting the geometrical requirements described in section "**Anchorage Locations and Geometries**" for 5-point anti-sub strap routing.
- Make sure the anchor point is located on the centre line of the seat.
- If you have to create an anchor point by yourself, strictly follow the procedures and WARNINGS in section "**Anchorage Locations and Geometries**".
- Assemble bolt and bracket as shown below,
- Use e.g. "Loctite 243" to secure bolt.

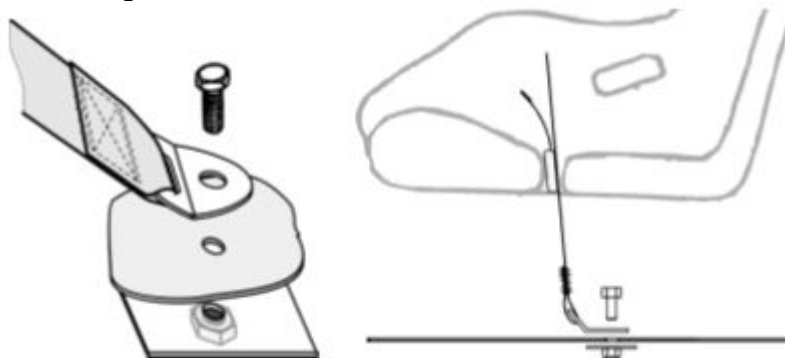

- Bolt-in and tighten. Follow all information as well as SAFETY INSTRUCTIONS and WARNING boxes provided under section titled “**Important Information about Bolts and Torques**”.
- Make sure the bracket is directed forward to allow even load on the webbing and anti-sub strap assembly during a crash.

Installation with end loop

This installation is commonly used for shoulder belt installation in open wheel race cars and requires a made to measure racing harness.

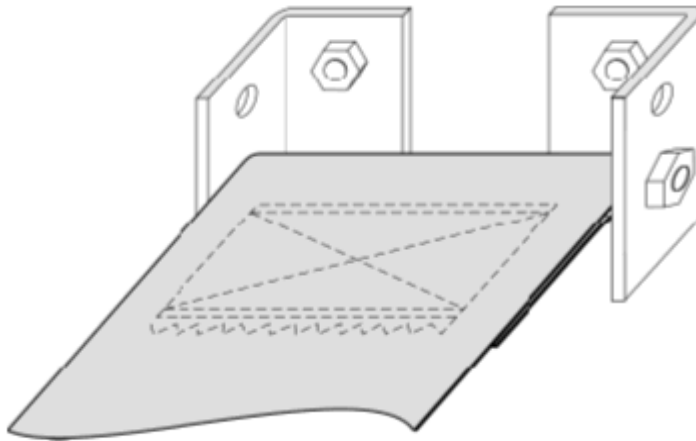

75 mm [3"] webbing installed to custom designed elbow bracket system.

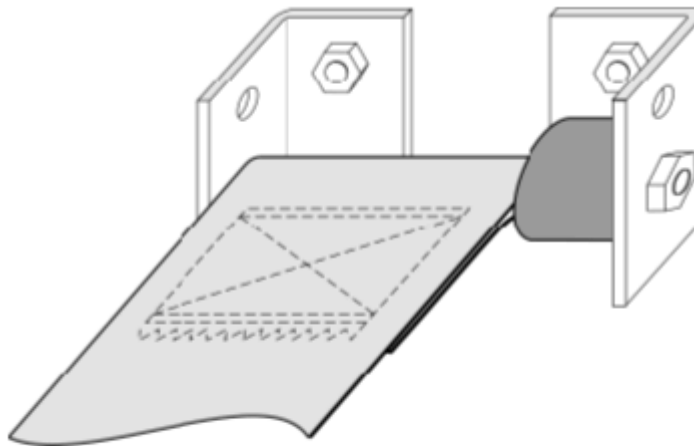

50 mm [2"] webbing of a HANS® shoulder belt installed to a 75 mm [3"] designed elbow bracket system.

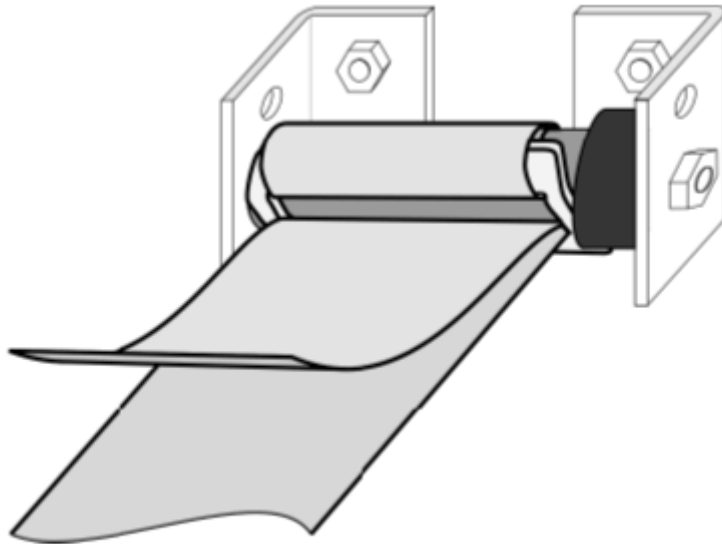

50 mm [2"] webbing with D-Ring slide of a HANS® specific shoulder belt installed to a 75 mm [3"] designed elbow bracket system.

 **WARNING**

Wrap mounted shoulder straps must be braced on each side so that the webbing can not move from side to side. Failure to secure the sideward movement of the wrap mounted shoulder straps could cause the belts to slide off Head and Neck Support, eliminating its effectiveness.

Never use bars of lower grade than the original. Lower grade bars may be too weak and may fail during an accident.

SEVERE INJURIES OR DEATH MAY OCCUR.

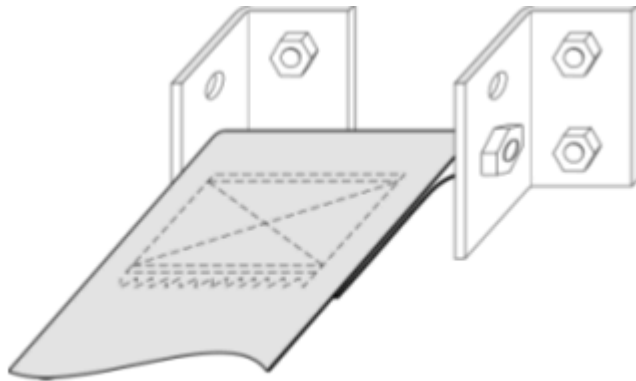

50 mm [2"] webbing of a HANS® specific shoulder belt installed to a elbow bracket system with elbow bracket installed reversal to create 50 mm [2"] distance.

- In case of a reversed installed elbow bracket, shorter bars but such of same diameter can be used.
- Replacement bars must be at least of same grade than the original one.

If the bracket allows different heights in installation, make sure to choose the one which makes the shoulder straps running horizontal or max 20° down from the shoulder or from HANS®.

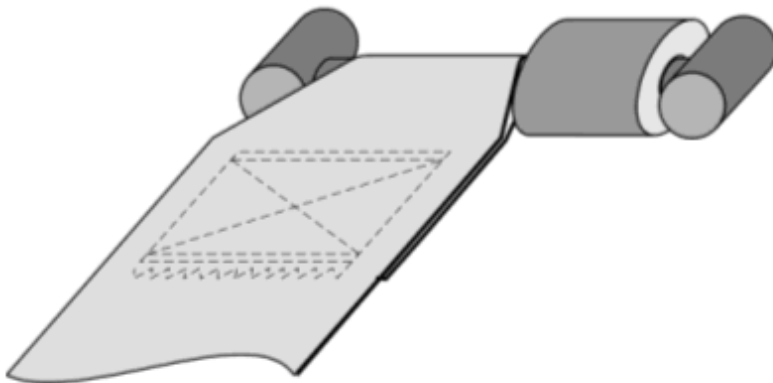

A fold in webbing installed to a bell bar system with spacer.

- Spacers used must fully fill the gap between the bar and the wall so webbing can not slide over.